

# FLUIDRA

# USA



8525 Mallory Rd. Jacksonville, FL 32220  
Office: (904) 378-0999 Fax: (904) 378-0408

## **POLTANK 34"** - Horizontal Commercial Sand Filtration System



### FEATURES

- Simplified trouble free operation
- Outstanding filtration efficiency
- Greatest level of convenience compared to other filter types
- Rugged non-corrosive, weather resistant design
- 50 psi operating pressure
- Guaranteed 34.5" O.D. tank diameter on two sides
- Patented 360° ABS slotted lateral and PVC diffuser provide balanced water flow through filter bed
- 10 year limited warranty
- Single and multiple tank configurations
- Reliable and efficient operational accessories
- NSF Certified

Form no. Poltank-34-spec  
Effective 2/16

## DESCRIPTION

Fluidra horizontal sand filtration systems are manufactured in Jacksonville, Florida using CNC controlled filament winding equipment. The tanks are constructed with a dual laminate process consisting of a non-continuous strand and roving inner structure combined with a filament wound outer structure. The tanks superior construction is resistant to fatigue associated with operational cycling, corrosion and scaling and will provide decades of reliable service.

The horizontal filters are designed for 50 psi operating pressures, available in 5 tank diameters providing 35 models. The filters are available in single, multiple and stacked tank configurations. The filter(s) come standard with a 16" round manway opening and cover, flanged influent/effluent ports, manual air vent and media/water drain combination port. The filters are NSF listed for filtration rates from 5 to 20 gpm/ft<sup>2</sup> of filter area with operating flows from 67 to 1500 gpm in a single tank. The tanks come fully assembled with an imbedded U.V. protection for outdoor installations.

Operational accessories including standard and custom manifold systems with or without unilever operation, semi and fully automatic backwash control systems and filter media can be purchased individually or with the filter tanks when ordering a system.

ORDERING INFORMATION												
Model No.	Tank Dia.	Filter Area Ft <sup>2</sup>	Filter/BW Rate 15 gpm	Filter Rate 20 gpm	Capacity			Cu. Ft. 1/8" 1/4" Gravel Ft <sup>3</sup>	#20 Sand Ft <sup>3</sup>	Total Media Ft <sup>3</sup>	Approx Ship Wt Lbs	Approx Oper. Wt Lbs.
					Gals. Per 60 min.	Gals. Per 120 min.	Gals. Per 240 min.					
34135-050-E	34.5	13.5	202.5	270.0	12,150	24,300	48,600	4.0	13.5	17.5	468	3,388
34153-050-E	34.5	15.3	229.5	306.0	13,770	27,540	55,080	4.5	15.2	19.7	496	3,805
34175-050-E	34.5	17.2	258.0	344.0	15,480	30,960	61,920	5.0	17.0	22.0	532	4,251
34193-050-E	34.5	19.3	289.5	386.0	17,370	34,740	69,480	5.5	19.0	24.6	570	4,743
34237-050-E	34.5	23.7	355.5	474.0	21,330	42,660	85,320	6.7	23.2	30.0	645	5,768

### General Notes:

- 1) Filters ship complete with overhead distribution assembly, lower collection assembly, two pressure gauges manual air relief, combination media/drain port.
- 2) Filters DO NOT include face piping manifolds and filter media which must be ordered separately
- 3) Filters are a maximum 34.5" O.D. on two sides

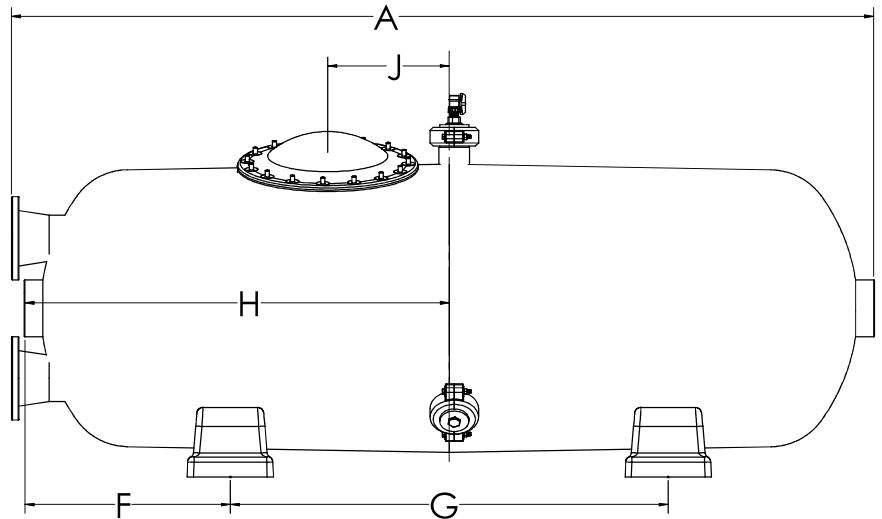
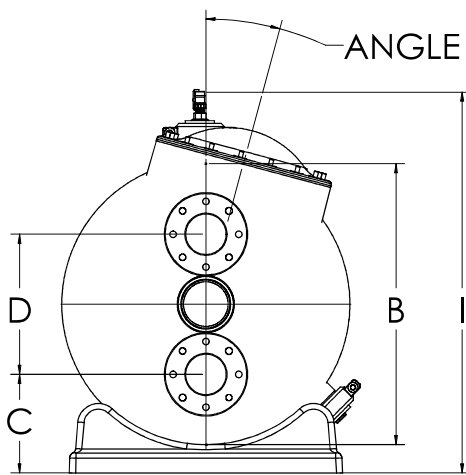

Model No.	OUTLINE DIMENSIONS											
	A	B	C	D	E	F	G	H	I	J	Port Size	Angle °
34135-050-E	70.1	34.5	12.0	16.5	4.9	16.6	33.3	33.3	41.2	24.8	4	30
34153-050-E	78.0	34.5	12.0	16.5	4.9	16.6	37.2	37.2	41.2	22.2	4	30
34175-050-E	86.4	34.5	12.0	16.5	4.9	16.6	41.4	41.4	41.2	24.3	4	30
34193-050-E	95.6	34.5	12.0	16.5	4.9	16.6	46.1	46.1	41.2	22.8	4	30
34237-050-E	115.0	34.5	12.0	16.5	4.9	16.6	55.7	55.7	41.2	23.6	4	30

## FILTER MANIFOLDS & ACCESSORIES

- Sch. 80 PVC pipe construction
- CEPEX PVC butterfly valves
- Zinc plated hardware
- Preassembled and hydro tested
- NSF Certified



Single Filter Manifolds

- FRP pipe supports
  - Vertical support pole & base
  - 2 pipe clamps & hardware
- Single lever linkage
  - Arms & linkage tie all valves together
  - Simplified operation



Manifold Support Kit

- Electric Actuator
  - 110 VAC
  - Manual override & visual position indicator
  - Torque limiter
  - BSR safety brake
  - Digital positioning system



Actuator

FILTER MEDIA ORDERING INFORMATION						
Tank Dia.	Filter Sand	Filter Sand Cu. Ft.	Filter Sand Shipping Weight	Support Gravel	Support Gravel Cu. Ft.	Support Gravel Shipping Weight
34.5	00596	0.5	50.0	GRAVEL-14	1.0	100.0

General Notes:

- 1) Filter Sand is a #20 Silica Sand with an Effective Size of .45mm to .55mm
- 2) Support Gravel is 1/8" x 1/4" Rounded & Washed.

OUTLINE DIMENSIONS MANIFOLD SYSTEM								
Model No.	Tank Dia.	Number of Filter Tanks	A	B	C	D	E	F
50203	34.5	1	16.2	N/A	N/A	11.4	7.0	10.0
06798	34.5	1	10.3	17.8	14.1	16.5	7.0	10.7
50204	34.5	1	19.9	N/A	N/A	11.4	8.0	11.9
20983	34.5	1	19.1	25.4	20.0	16.5	8.0	14.8
06800	34.5	1	10.3	24.4	14.1	24.0	7.0	10.7
20997	34.5	1	19.1	29.8	20.0	25.9	8.0	14.8

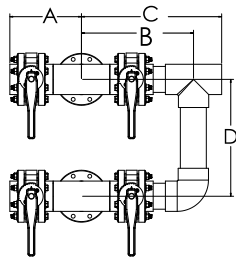

4 Valve Manifolds

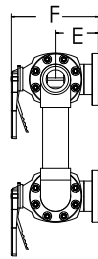

2 Valve Manifolds

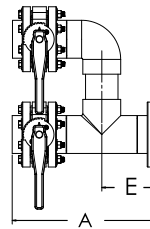

Dial valve

MANIFOLD ORDERING INFORMATION											
Model No.	Tank Dia.	Number of Filter Tanks	Number of Valves	Max. Flow GPM	Manifold Valve & Port Size	Tank Port Size	Manifold & Valve Material	Pipe Support Kit	Single Lever Linkage Kit	Electric Actuator	
50203	34.5	1	2	205	3	4	PVC	00844	50203-SLL	A1012	
06798	34.5	1	4	205	3	4	PVC	00844	06798-SLL	A1012	
50204	34.5	1	2	355	4	4	PVC	00845	50204-SLL	A1013	
20983	34.5	1	4	355	4	4	PVC	00845	18203-5000	A1013	
06800	34.5	1	5	205	3	4	PVC	00844	N/A	A1012	
20997	34.5	1	6	355	4	4	PVC	00845	N/A	A1013	

General Notes:

- 1) Single Tank manifolds require 2 pipe supports, 5 valve manifolds require 3 Pipe Supports
- 2) Electric Actuators are Used with Semi Automatic or Automatic Backwash Systems. Each Valve in the System Requires an Actuator
- 3) Semi Automatic and Automatic Backwash Control Information Available in Separate Data Sheet

## MATERIALS & DESIGN

### FILTER SYSTEM

The filter system specified under this section shall be a pressurized Hi-Rate Permanent Media Filter design as manufactured by Fluidra USA.

The filter system shall be of the horizontal type suitable for a single grade of media and shall be certified for swimming pool/ spa use by NSF International to NSF/ ANSI Standard 50. The filter certification shall be for a maximum flow of 20 gallons per minute per square foot of filter area.

The filter tank system shall consist of a 34½" horizontal filter tank(s), internal distribution system, internal air vent, manway opening/ cover, external vent and drain assembly. The tank(s) shall be manufactured in a fully assembled state with the external air vent disassembled for shipping. The filter(s) shall be designed and manufactured in a manner to allow for shipping under normal conditions without internal damage to the filter.

### FILTER AREA

The filter plant shall consist of \_\_\_\_\_, 34" Horizontal Hi-Rate Permanent Media Filter(s) with a total effective filter area of \_\_\_\_\_ square foot each. When operating at \_\_\_\_\_ gpm per square foot of filter area, the filter system will have a capacity of filtering \_\_\_\_\_ gallons in \_\_\_\_\_ minutes.

### FILTER TANK(S)

The filter tank(s) shall be 34" in diameter with a total length of \_\_\_\_\_" and shall be constructed Fiberglass resin with a maximum working pressure of 50 psi, hydrostatically tested to 1.1 x maximum working pressure and designed to a minimum of 5:1 safety factors.

Each filter tank(s) shall consist of a body and two dished heads manufactured with a dual wall structure consisting of a contact molded inner structure and a filament wound outer structure. The inner structure shall be manufactured with Woven Roving and Chop Strand Mat on a male mold in a two or three-piece design, depending on length, and joined together with secondary joint(s) before applying the outer structure. The outer structure shall be filament wound in both radial and axial geometric patterns to provide maximum strength in all load directions. The dished heads and body thicknesses shall be designed according to ASME Section X requirements confirmed through calculations and a Finite Element Stress Analysis. The outer structure of the tanks shall be seamless and constructed of pigmented resin to provide a professional exterior finish.

The filter tank(s) shall be mounted on two FRP saddle supports that are permanently bonded to the tank through the use of a structural adhesive system. The tank support saddles shall be designed in compliance to all relevant seismic code requirements when anchored to the manufacturer's specifications.

A 16" round flanged manhole complete with FRP cover, O-ring and bolts shall be located in the body of the filter tank(s). All o-ring contact points on the manhole flange and cover shall have a smooth finish to provide a continuous watertight seal.

A molded 3" combination media dump port and drain complete with a ABS media retainer and flange type closure shall be located in the side shell of the filter tank(s).

A molded ¾" external air relief complete with PVC ball valve shall be located in the side shell of the filter tank(s).

The influent and effluent ports shall be flanged to facilitate proper connection of both internal and external piping. The influent/ effluent ports shall consist of FRP flanges designed according to ASTM-PS 15-69-NBS with a ANSI standard 150 lb. bolt pattern.

### INTERNAL DISTRIBUTION/COLLECTION SYSTEM

The filter tank equipment shall include an upper distribution system and lower collection system, hydraulically balanced to prevent filter media migration during filter operation and/ or backwash.

The upper distribution system shall include hydraulic diffusers manufactured of injection molded PVC plastic, located in multiple sets of two over the filter bed. They shall be piped to a Schedule 80 PVC distribution header with Schedule 80 PVC pipe and fittings appropriately sized to maintain proper flow velocities throughout the entire distribution system.

The lower collection system shall consist of a Schedule 80 PVC header and molded ABS plastic laterals with .009" tapered slots designed to retain a single grade of filter media with .23 mm particle size. The internal collection system shall be designed to promote media bed circulation during backwash while providing minimal head loss during filtration.

### FILTER MEDIA

Filter media shall consist of a carefully selected grade of hard, uniformly graded silica with a minimum combined mean percent of silica by weight of 90%, which shall be free of limestone or clay. The silica shall be angularly shaped particles with a particle size between .45mm and .55 mm and a roundness value between 0.0 and 0.15. Round or Sub-rounded particle shapes will not be acceptable. The uniformity coefficient shall not exceed 1.50 with a specific gravity of not less than 2.5 with a minimum hardness of 7 mhos. Support media shall be hard, water rounded silica material, uniformly graded ½" – ¼" gravel, no limestone or clay shall be present. Alternate media must be approved by the filter manufacturer.

### PRESSURE GAUGE PANEL

The pressure gauge panel shall consist of two 2½" diameter Flutter Guard gauges scaled from 0-100 PSIG. The pressure gauges shall be mounted in an injection molded panel. The pressure gauges shall be connected to influent and effluent pressure points with air relief cocks, compression fittings and semi-rigid PVC tubing.

The filter system as outlined herein shall be Fluidra USA Model No. \_\_\_\_\_.

### FACE PIPING

The face piping shall be fabricated in a fully assembled state by the filter manufacturer of Schedule 80 PVC pipe and fittings. Flanges shall be located to allow for easy disassembly to prevent damage during shipping.

The butterfly valves shall be constructed of PVC with aluminum handles. The valve shall have EPDM and PE that provide shut off up to 150 psi while sealing the valve stem from exposure to internal liquids. The face piping shall be certified by NSF International as an operational component for the filter system carrying the same pressure and flow ratings as the filter tank.

### SINGLE LEVER LINKAGE

A clevis and rod linkage system shall connect the butterfly valves provided with the face piping. Simplified operation shall be achieved through the raising or lowering of a single operating handle.

Connecting components shall vary in length to provide suitable mechanical advantage to operate the system. All valves shall operate simultaneously to eliminate the possibility of water hammer. The linkage components shall be constructed of T304 stainless steel designed to allow for individual valve adjustment to ensure proper positioning of the valves.

### ELECTRIC ACTUATOR

An electromechanical actuator shall be mounted on each valve of the face piping kit. The actuator shall be automatically operated during initiation of the backwash cycle and return to filter cycle through the use of 115-volt AC totally enclosed motor sized at a 2:1 safety factor to the seating torque of the butterfly valve with a torque limiter. The actuator shall have a closure time of 15 seconds/ 90 degrees with a manual override, BSR safety brake to prevent valve slippage and visual position indicator. The actuator shall have a digital positioning system with dual open and close limit switches for feed back to the backwash control system.